

Vickers® Electrohydraulic Controls



Proportional Directional Valves with Feedback

K(B)FD/TG4V-3, 1*1/2* Series

Pressures to 350 bar (5000 psi)

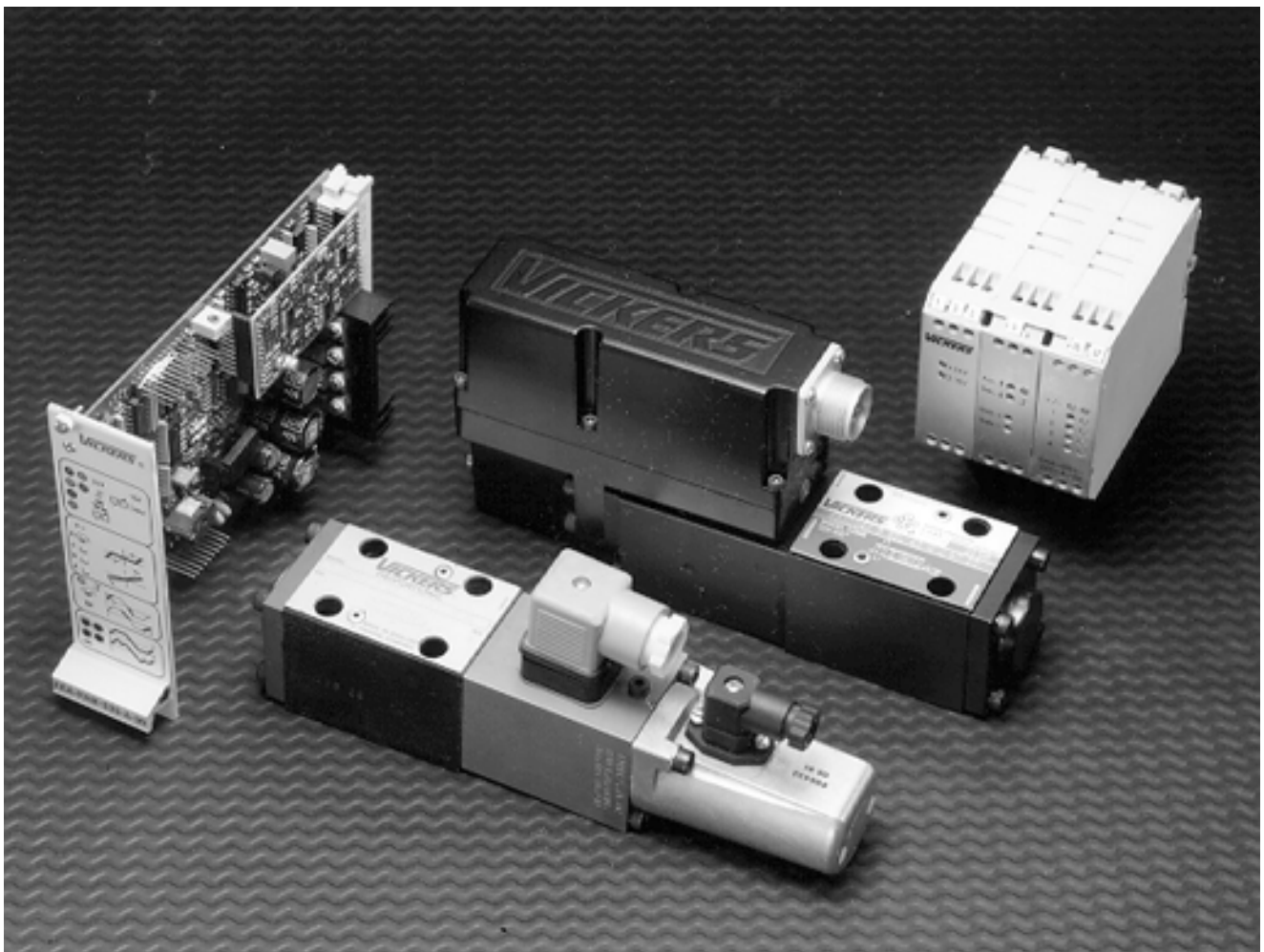

This product has been designed and tested to meet specific standards outlined in the European Electromagnetic Compatibility Directive (EMC) 89/336/EEC, amended by 91/263/EEC, 92/31/EEC and 93/68/EEC, article 5. For instructions on installation requirements to achieve effective protection levels, see this leaflet and the Installation Wiring Practices for Vickers Electronic Products leaflet 2468. Wiring practices relevant to this Directive are indicated by  Electromagnetic Compatibility (EMC).

5071.00/EN/0298/A

VICKERS

Introduction

General Description

Vickers proportional valves shown in this catalog are designed to provide a controlled oil flow in direct proportion to a command signal. They are available in two types; a double solenoid version that will provide reversible flow to an actuator and a single solenoid throttle version that provides a single direction of flow. Hydrostats are available for load compensation and parallel flow path modules are available that will boost the flow capacity of single solenoid throttle versions to nearly twice that of the standard valve.

Additionally, both of these valve types can be supplied with or without an integral amplifier built directly onto the valve.

KFD/TG4V-3

This version is supplied **without** the integral amplifier.

Features and Benefits

- Wide range of spool and flow rate options.
- Electronic feedback LVDT ensures accurate spool position control.
- Internal current feedback provides optimal control.

- Vibration and shock tested.
- Supported by a broad range of amplifiers and auxiliary function modules.
- Full CE electromagnetic compatibility.

KBFD/TG4V-3

A range of proportional directional and throttle valves **with** integral control electronics. Factory-set adjustments of gain, spool deadband compensation and offset ensure consistent repeatability valve-to-valve.

The only electrical inputs required are power supply (24V) and a voltage command signal of $\pm 10V$. The amplifier is housed in a robust metal enclosure, sealed against ingress of water and other fluids. Electrical connections are via a standard 7-pin plug.

A spool position monitor pin allows the function of the valve to be electrically monitored. Ramp functions, if required, can be generated externally.

Features and Benefits

- Factory-sealed adjustments ensure valve-to-valve reproducibility
- Installation wiring reduced and simplified.
- Standard 7-pin connector.
- Standard 24V DC supply with wide tolerance band.
- Standard $\pm 10 V$ DC command signals.
- Valve with integrated amplifier selected, ordered, delivered and installed as one performance-tested package.
- Spool position monitor pin to help with troubleshooting.
- Simple valve removal and replacement for service (plug & play).
- Vibration and shock tested.
- Auxiliary DIN rail mounted electronic function modules available.
- Full CE electromagnetic compatibility.
- IP67 valve environmental protection rating.
- Optional valve enable function.

Typical Section View

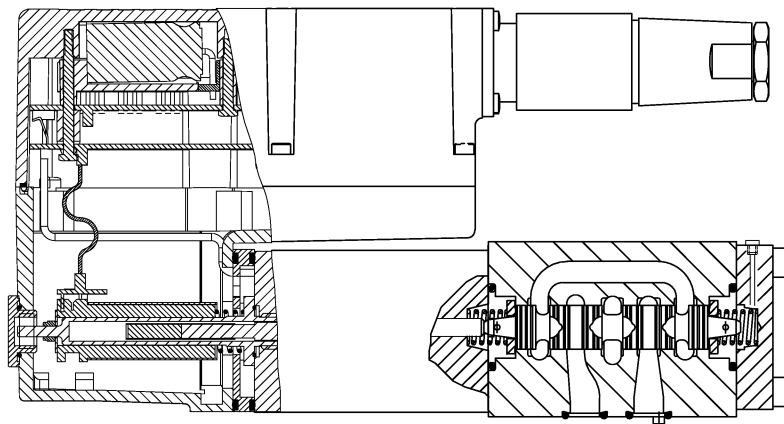

KBFD/TG4V-3-*C, 1* Design

Contents

Introduction	2
Typical section	2
Model code	4
Spool data	5
Functional symbols	5
Operating data	
Kbfd/TG4V-3	6
Kfd/TG4V-3	7
Kbfd/TG4V-3 & Kfd/TG4V-3	7
Pressures and flow rates	7
Performance curves	
Power capacity envelopes, single solenoid models	8
Power capacity envelopes, double solenoid models	8
Flow gain curves	9
Frequency response	9
Installation dimensions	
Kfdg4V-3	10
Kftg4V-3	10
Kbfdg4V-3	11
Kbftg4V-3	11
Subplates and Mounting Surfaces	
Parallel path flow module	12
Subplate functional symbol	12
Interface with additional drain port	12
Installation dimensions, Single station subplate KDGVM-3-1*-R	13
Installation dimensions, Single station subplate KDGVM-3-676803-1*	13
Mounting surface interface to ISO 4401 (Size 03)	13
Electrical Information	
Block diagram	14
Typical connection arrangements	15
Application Data	16

Model Code

K (B)F * G4 V -3 - ** * ** * ** - Z - (V) - (M) - (U1) - (*) - H - * - ***

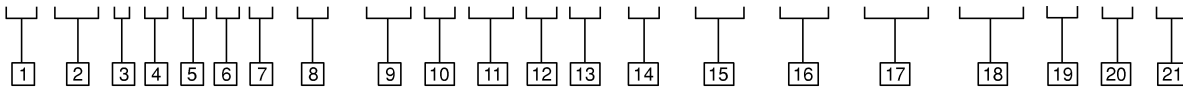

1 Valve type

K – Proportional valve

2 Integral amplifier

B – Integral amplifier “B” series
Omit for models *without* integral amplifier

3 Feedback arrangement

F – Spool position

4 Control type

D - Directional valve
T - Throttle valve

5 Mounting

G – Subplate mounted

6 Operation

4 – Solenoid operated

7 Pressure rating

V – 350 bar (5000 psi) on ports P, A, & B

8 Interface

3 – ISO 4401, size 03-02-0-94
ANSI/B93.7M-D03

9 Spool type (center condition) (see spool data, page 5)

2 – Closed center (all ports)
33 – P port closed, bleed A & B to T

10 Spool/spring arrangement

B – Spring centered single solenoid valve (solenoid “B” only) Solenoid “A” for “V” version
C – Spring centered, dual solenoid

11 Spool flow rating

$\Delta p = 5$ bar (75 psi) per metering flow path, e.g. B to T For actual maximum flow refer to power capacity envelope curves page 8).

03 – 3 L/min (0.79 USgpm) Δ
07 – 7 L/min (1.85 USgpm) \blacktriangle
13 – 13 L/min (3.43 USgpm) \blacktriangle
20 – 20 L/min (5.28 USgpm) \blacktriangle
28 – 28 L/min (7.40 USgpm) \square

\blacktriangle Meter-in/meter-out
 \square Meter-out only; type 2 spool only

Δ Fine meter-in/meter-out

12 Spool metering type

N – Meter-in and meter-out
F – Fine meter-in and meter-out
S – Meter-out only

13 Flow rating (“B” port flow for asymmetric spools) K(B)FDG valves only

10 – 10 L/min (2.64 USgpm)
(20N10 only)
Omit for symmetrical spools

14 Manual overrides

Z– No manual overrides

15 Solenoid energization identity

(non-integral amplifier types only, omit for valves with integral amplifier)

V – Solenoid “A” is at port “A” end and Solenoid “B” is at port “B” end independent of spool type
Blank US ANSI B93.9 standard (energize solenoid “A”, flow symbol is (P→A))

16 LVDT plug

(omit for valves with integral amplifier)
M – Standard LVDT (mating plug supplied)

17 Solenoid connector

(omit for valves with integral amplifier)
U1 – ISO 4400/DIN 43650, non-integral amplifier type only (mating plug supplied)

18 Electrical connection (KBF valves only)

PC7 – 7 pin connector without plug
PE7 – 7 pin electrical plug with mating half
PH7 – As PE7 but with pin “C” used for enable signal
PR7 – As PC7 but with pin “C” used for enable signal

19 Coil rating

H – 24 VDC amplifier supply

20 Port T pressure limit code

6 – for 2C**S spools
7 – for all other spools

21 Design number

1* and 2* series. Subject to change



Warning

Valves with integral amplifiers are supplied with or without the metal 7-pin plug. The Vickers plug, part no. 934939, must be correctly fitted to ensure that the EMC rating and IP67 rating are achieved. The plug retaining nut must be tightened with a torque of 2-2,5 Nm (1.5-2.0 lbf ft) to effect a proper seal)

Spool Data

Spool Symbols

Available Spools for K(B)FDG4V-3

Spool type 2C**N, meter-in/meter-out

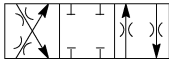

Spool type 2C20N10, assymetric flow

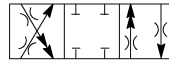

Spool Type 2C28S, meter-out only

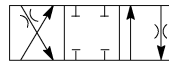

Spool type 33C**N, meter-in/meter-out

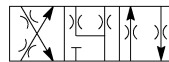

Spool type 33C20N10, assymetric flow

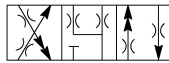

Available Spools for K(B)FTG4V-3

Spool type 2B**N, meter-in/meter-out

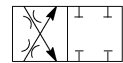

Spool Types and Flow Ratings

Symmetric Spools

Base line starting at $\Delta p = 5$ bar (75 psi) per metering flow path, e.g. B to T. For actual maximum flow refer to power capacity envelope curves.

Spool code	Spool symbol	Flow rating
For K(B)FDG4V-3 valves:		
2C03F	2C	3 L/min (0.79 USgpm)
2C07N	2C	7 L/min (1.85 USgpm)
2C13N	2C	13 L/min (3.43 USgpm)
2C20N	2C	20 L/min (5.28 USgpm)
2C28S	2C	28 L/min (7.40 USgpm)
33C03F	33C	3 L/min (0.79 USgpm)
33C07N	33C	7 L/min (1.85 USgpm)
33C13N	33C	13 L/min (3.43 USgpm)
33C20N	33C	20 L/min (5.28 USgpm)
For K(B)FTG4V-3 valves:		
2B03F	2B	03 L/min (0.79 USgpm)
2B07N	2B	07 L/min (1.85 USgpm)
2B13N	2B	13 L/min (3.43 USgpm)
2B20N	2B	20 L/min (5.28 USgpm)

Asymmetric Spools

Figure preceding metering type designator, "N" (e.g. 2C***N) is flow rating P-A, or A-T ("A" port flow); figure after "N" (N***) is flow rating P-B, or B-T ("B" port flow).

Spool code	Spool symbol	Flow rating
For K(B)FDG4V-3 valves:		
2C20N10	2C	20 L/min (5.28 USgpm), "A" port flow 10 L/min (2.64 USgpm), "B" port flow
33C20N10	33C	20 L/min (5.28 USgpm), "A" port flow 10 L/min (2.64 USgpm), "B" port flow

Functional Symbols

Model Types KBFDG4V-3

proportional directional valve (with integrated electronics)

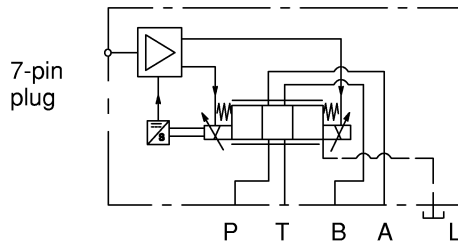

Model Types KFDG4V-3

proportional directional valve (requires amplifier card)

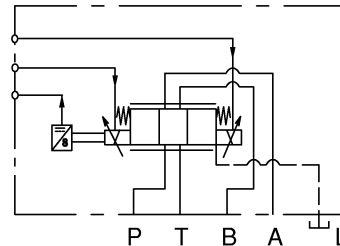

Model Types KBFTG4V-3

proportional throttle valve (with integrated electronics)

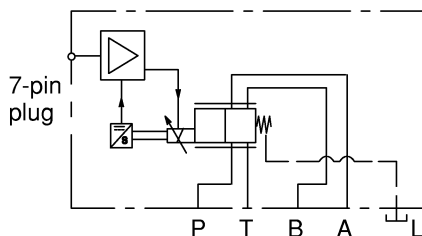

Model Types KFTG4V-3

proportional throttle valve (requires amplifier card)

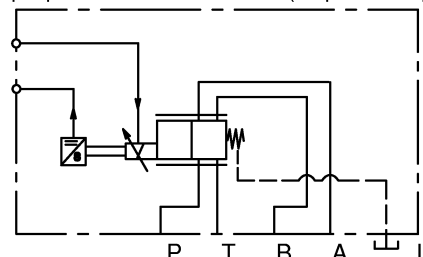

Operating Data

Valves w/amplifier

KBFD/TG4V-3 Valves with integral amplifier. Data is typical with fluid at 36 cSt (168 SUS) and 50°C (122°F).

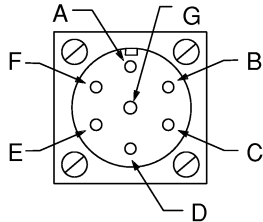
Power supply	24V DC (21V to 36V including 10% peak-to-peak max. ripple) max current 3A																		
Command signal Input impedance Common mode voltage to pin B	0 to +10V DC, or 0 to -10V DC, or -10 V to +10 V DC 47 kΩ 18V (max)																		
Valve enable signal for model codes PH7 & PR7 Enable Disable Input impedance	>8.5V (36V max) <6.5V 10 kΩ																		
7-pin plug connector  View of pins of fixed half	<table border="1"> <thead> <tr> <th>Pin</th> <th>Description</th> </tr> </thead> <tbody> <tr> <td>A</td> <td>Power supply positive (+)</td> </tr> <tr> <td>B</td> <td>Power 0V</td> </tr> <tr> <td>C</td> <td>Command/Monitor 0V (PE7 & PC7)</td> </tr> <tr> <td>C</td> <td>Valve enable (PH7 & PR7)</td> </tr> <tr> <td>D</td> <td>Command signal (+)-non-inverting input</td> </tr> <tr> <td>E</td> <td>Command signal (-)-inverting input</td> </tr> <tr> <td>F</td> <td>Monitor input</td> </tr> <tr> <td>G</td> <td>Protective ground</td> </tr> </tbody> </table>	Pin	Description	A	Power supply positive (+)	B	Power 0V	C	Command/Monitor 0V (PE7 & PC7)	C	Valve enable (PH7 & PR7)	D	Command signal (+)-non-inverting input	E	Command signal (-)-inverting input	F	Monitor input	G	Protective ground
Pin	Description																		
A	Power supply positive (+)																		
B	Power 0V																		
C	Command/Monitor 0V (PE7 & PC7)																		
C	Valve enable (PH7 & PR7)																		
D	Command signal (+)-non-inverting input																		
E	Command signal (-)-inverting input																		
F	Monitor input																		
G	Protective ground																		
Electromagnetic compatibility (EMC): Emission (10 V/m) Immunity (10 V/m)	EN 50081-2 EN 50082-2																		
Threshold command voltage (minimum voltage for minimum flow)	0.25V																		
Monitor signal (pin F) KBFD valves KBFT valves	± 10V DC for full spool stroke 0 to -10V DC for full spool stroke																		
Output impedance	10kΩ																		
Power stage PWM frequency	10 kHz nominal																		
Step input response with flow through P-A-B-T Δp=5 bar (75psi) per metering path, e.g. P-A Required flow step: 0-100% 100% - 0 +90 - -90% (KBFDG4V-3 only)	Time to reach 90% of required step: 15 ms 15 ms 22 ms																		
Reproducibility, valve-to-valve (at factory settings): Flow at 100% command signal	≤ 5%																		
Protection: Electrical Environmental	Reverse polarity protected IEC 144, Class IP67																		
Ambient air temperature range for full performance Oil temperature range for full performance	0° C to 70° C (32° F to 158° F) 0° C to 70° C (32° F to 158° F)																		
Minimum temperature at which valves will work at reduced performance	-20° C (-4° F)																		
Storage temperature range	-25° C to +85° C (-13° F to +185° F)																		
Supporting products: Auxiliary electronic modules (DIN -rail mounting): EHA-CON-201-A2* signal converter EHD-DSG-201-A-1* command signal generator EHA-RMP-201-A-2* Ramp generator EHA-PID-201-A-2* PID controller EHA-PSU-201-A-10 Power supply	See catalog GB 2410A See catalog GB 2470 See catalog GB 2410A See catalog GB 2427 See catalog GB 2410A																		

Operating Data

Valves w/o amplifier

KFD/TG4V-3 Valves without integral amplifier (requires a Eurocard amplifier, refer to Supporting Products)

Max current, at 50° C (122° F) ambient	2,7 A
Coil resistance, at 20° C (68° F)	1,87Ω
Step response: Step size (% of max spool stroke): 0 to 100% 100% to 0 +90 to -90% (KFDG4V-3 only)	Time to reach 90% of required step: 18 ms 19 ms 30 ms
Type of protection, with electrical plugs fitted correctly	IEC 144, Class IP67
Electromagnetic compatibility (EMC) Emission (10 V/m) Immunity (10 V/m)	EN 50081-2 EN 50082-2
Maximum allowable ambient air temperature Maximum allowable oil temperature	60° C (140° F) 60° C (140° F)
Supporting products: Eurocard amplifiers EEA PAM 533 A/B/C/D/E/F	See catalog GB 2464

KFD/TG4V-3 and KBFD/TG4V-3 Valves (all valves)

Relative duty factor	Continuous rating (ED = 100%)
Hysteresis with flow through P-A-B-T	< 1% of max stroke (center-to-offset)
Mass: KFDG4V-3 KBFDG4V-3 KFTG4V-3 KBFTG4V-3	2,7 kg (5.9 lb) approx. 3,1 kg (6.8 lb) approx. 2,1 kg (4.6 lb) approx. 2,5 kg (5.5 lb) approx.
Portable test equipment EHA TEQ 700 A 20 EBA TEQ 706 A 10	See catalog GB 2462 See catalog GB 2315

Pressures and Flow Rates

Maximum pressures, bar (psi)

Model	Port L condition	Ports P, A, B	T	L
All models for normal usage (L port not connected)	Normally blocked by mounting surface	315 (4500)	160 (2300)	160 (2300)
		350 (5000)	105 (1500)	105 (1500)
For K(B)FDG4V-3-**C**N/E-Z models only, a higher "T" port pressure is allowed if the "L" port is connected directly to tank	Drained directly to tank	350 (5000)	210 (3000)	10 (150)

Performance Curves

Power Capacity Envelopes

Single solenoid models: K(B)FTG4V-3

Spool types as noted

Subject to maximum pressure limitations according to model type. See "Maximum Pressures" on page 7.

Single Flow Path

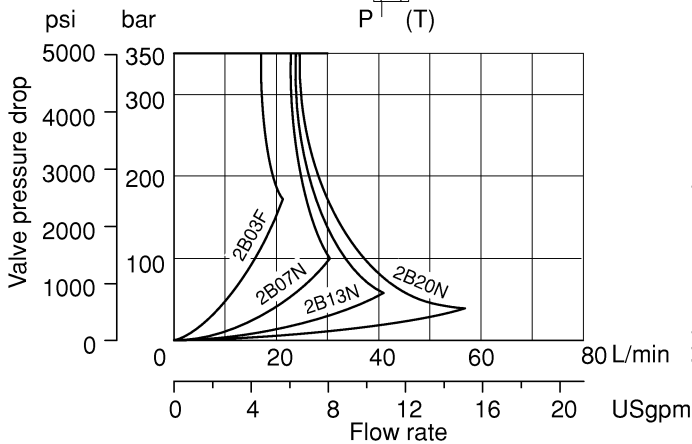
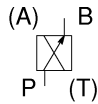

Looped Flow Path

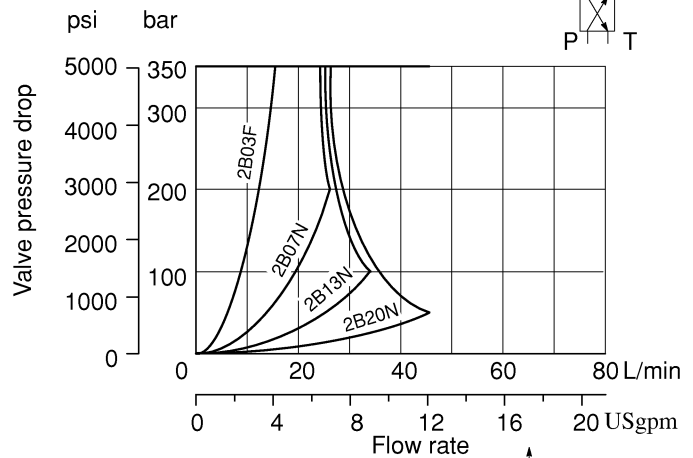

Parallel Flow Path

Use parallel flow path module KDGMA-3-616265-10 (see page 12)

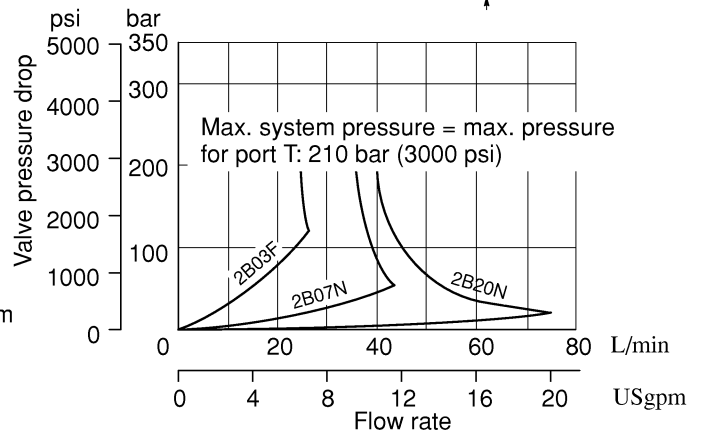
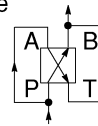

Double Solenoid Models: K(B)FDG4V-3

Spool types as noted

Single Flow Path

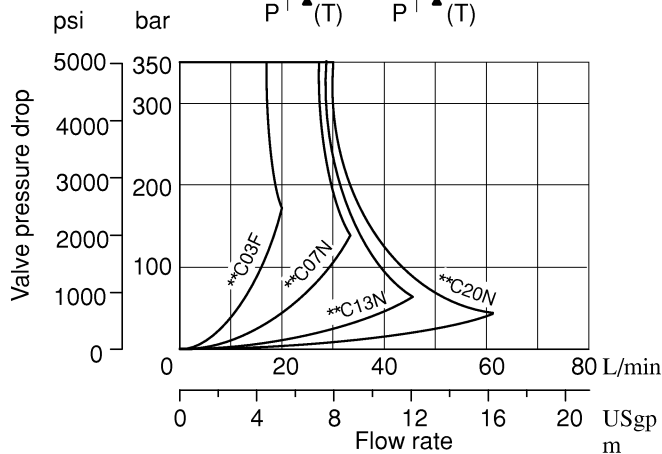
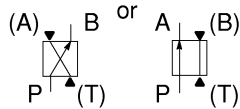

Looped Flow Path

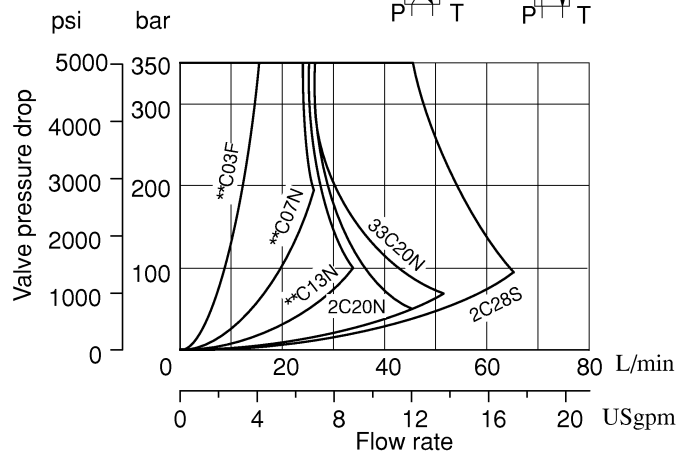
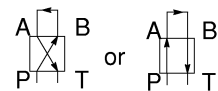

Flow Gain Curves

K(B)FD/TG4V-3

Spool types as noted

When using the single solenoid throttle valve version (K*FT) a parallel flowpath module (page 12) can be used to approximately double the flow rate.

KBF valves are preset at the factory to compensate for the effect of spool overlap.

Curves shown include deadband compensation provided for the KF valve by the Vickers Eurocard Amplifier EEA-PAM-533-*32 (user adjustable)

Single flowpath (e.g. P-A) pressure drop, $\Delta p = 5 \text{ bar (72 psi)}$ ■.

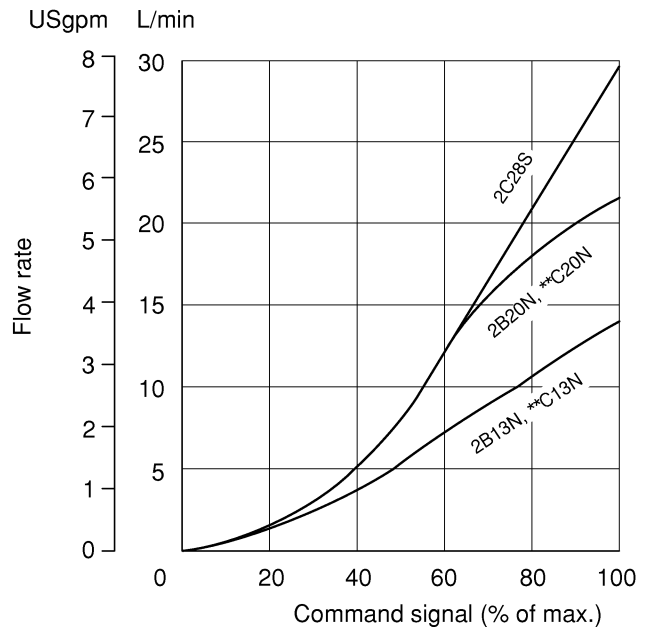
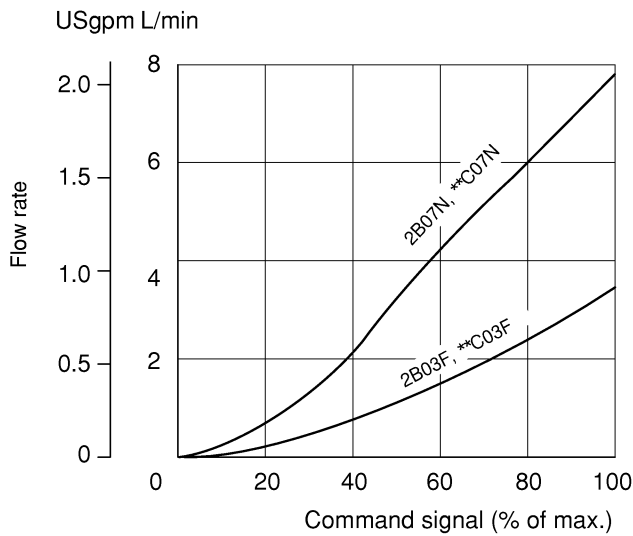

■ At other Δp values and within the power capacity envelopes, flow rates approximate to:

$$Q_x = Q_d \sqrt{\frac{\Delta p_x}{\Delta p_d}}$$

where $Q_d =$ Datum flow rate

$\Delta p_d =$ Pressure drop at datum flow rate

$\Delta p_x =$ Required Δp

Frequency Response (Typical)

For an amplitude of $\pm 25\%$ max. stroke about the 50% position, at Δp (P-B) = 5 bar (72 psi)

KBFD/TG4V-3

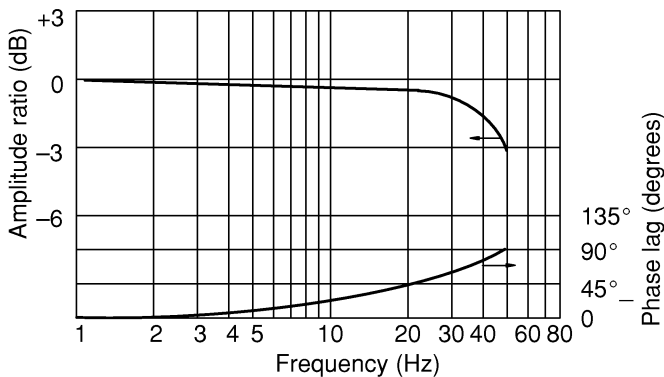

KFD/TG4V-3

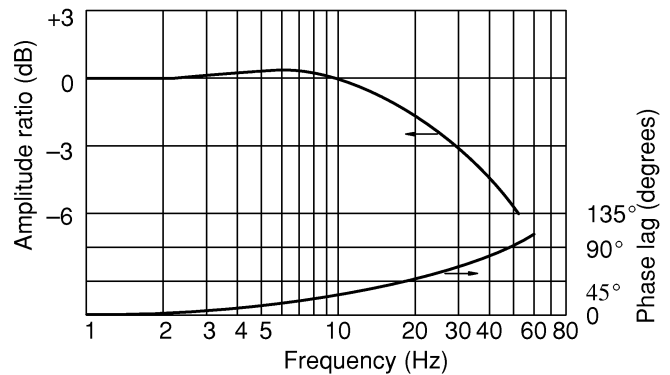

Installation Dimensions

KFDG4V-3

3rd angle
projection

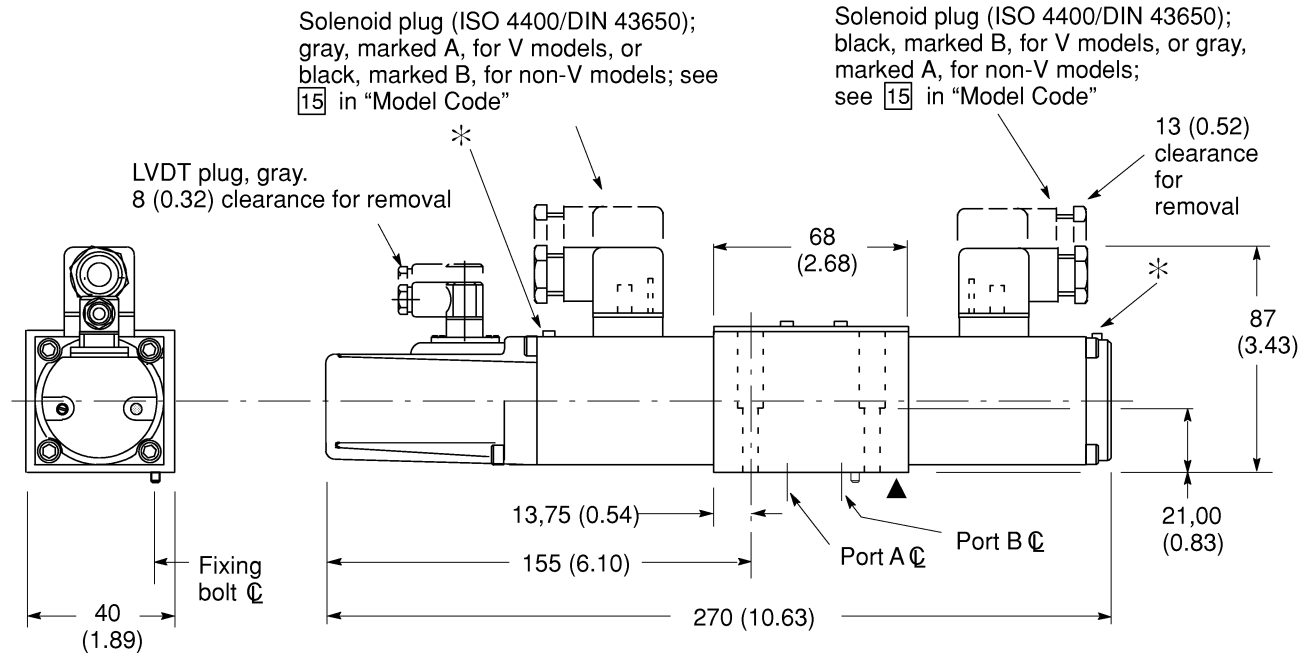
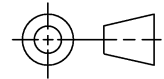

KFTG4V-3

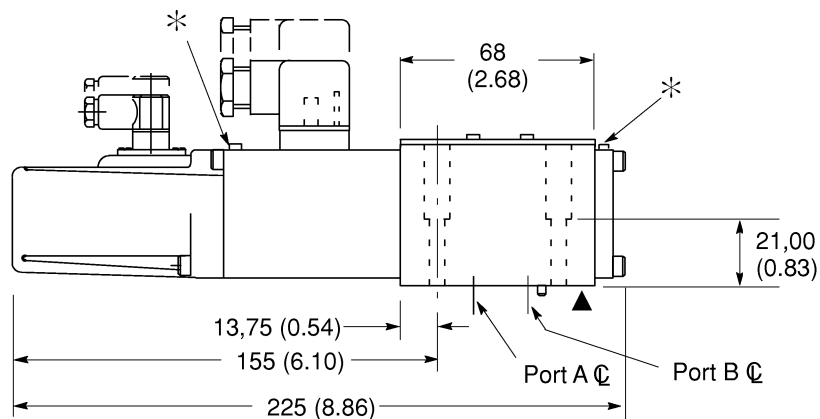

▲ Mounting surface seals supplied

*Note: Bleed screw locations Air bleed, Socket Head Cap Screw. Torque to 2,5-3,0 Nm (2.0-2.5 lbf ft)

NOTE: For optimum valve operation, bleed the air from the proportional solenoids at initial start-up. This may be done as follows:

- The valve may be pressurized by removing the bleed screws until no bubbles appear and then reinstalling bleed screws, or...
- Remove both bleed screws, and use a standard oil can nozzle to pump fluid in one side until it flows, free of air bubbles, out the other side. Reinstall screws.

If there is no inherent back pressure in the tank port of the circuit do not allow the tank line to empty. This may be prevented by installing a check valve in the tank line. The cracking pressure of the check valve should be in the range of 22 - 45 psi (1.5 - 3 bar)

KBFDG4V-3

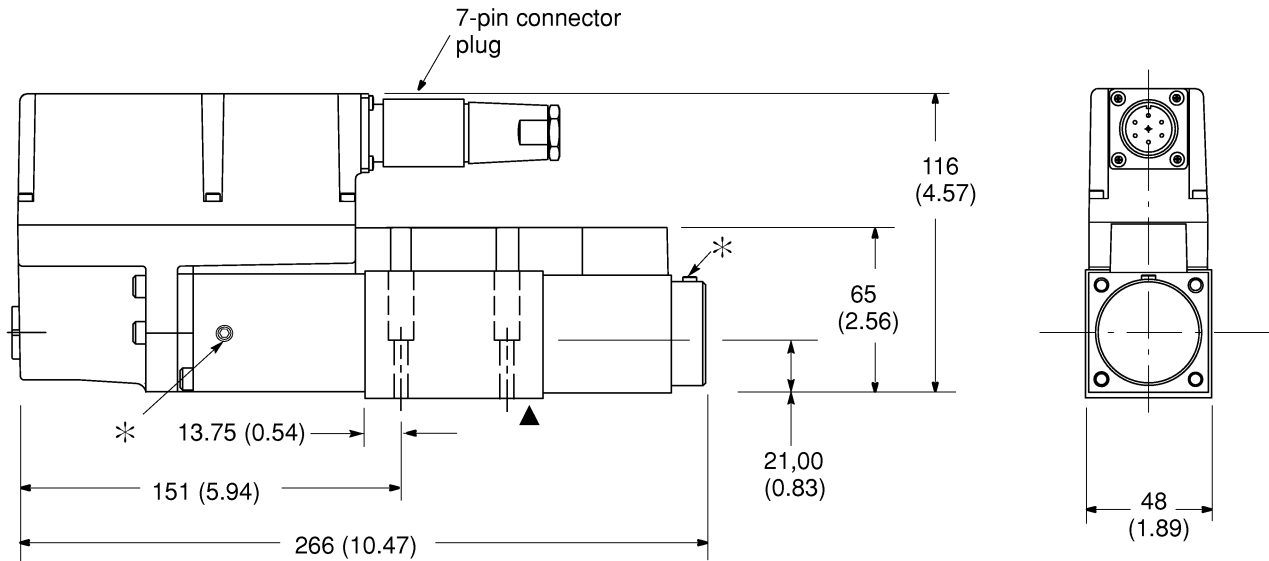

KBFTG4V-3

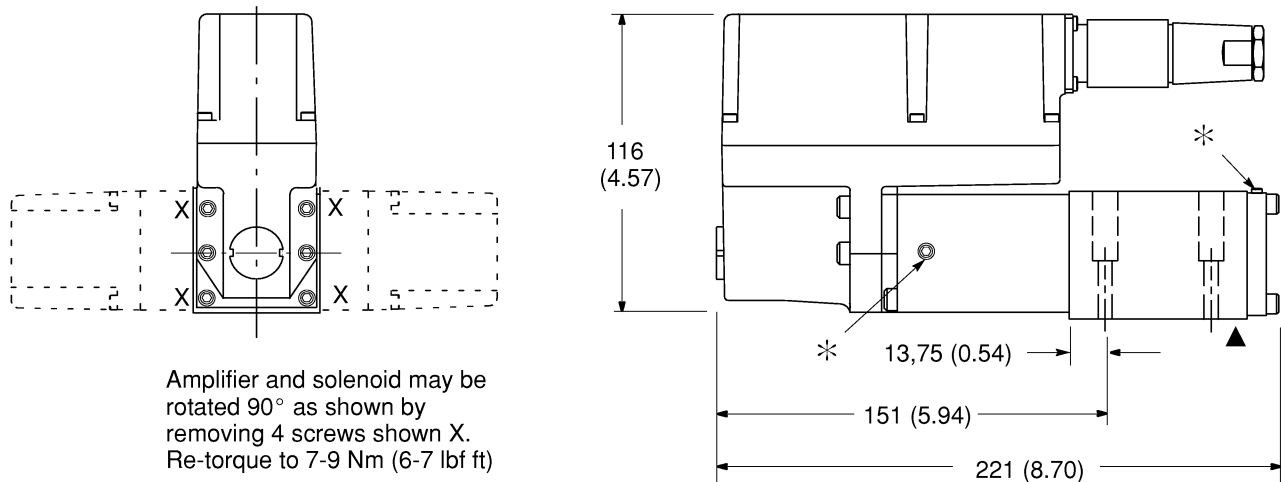

Amplifier and solenoid may be rotated 90° as shown by removing 4 screws shown X. Re-torque to 7-9 Nm (6-7 lbf ft)



Warning

Valves with integral amplifiers are supplied with or without the metal 7-pin plug. The Vickers plug, part no. 934939, must be correctly fitted to ensure that the EMC rating and IP67 rating are achieved. The plug retaining nut must be tightened with a torque of 2-2,5 Nm (1.5-2.0 lbf ft) to effect a proper seal)

For mounting surface dimensions and sub-plate options, see page 12.

*Note: Bleed screw locations *Air bleed, Socket Head Cap Screw. Torque to 2,5-3,0 Nm (2.0-2.5 lbf ft)*

▲ *Mounting surface seals supplied*

Parallel Path Flow Module

Size 03 Parallel-Flow-Path Module KDGMA-3-616265-1*

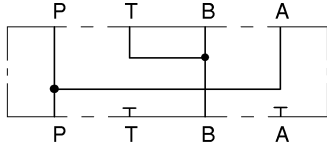

Typically used for doubling effective flow capability of single solenoid proportional valves (throttle valves), as illustrated in "Typical Applications".

▲ A , T_A and T_B ports at subplate face are blind holes fitted with O-seals.

4 holes $\varnothing 5,6$ (0.22 dia), counterbored to $\varnothing 9,5$ (0.374 dia)

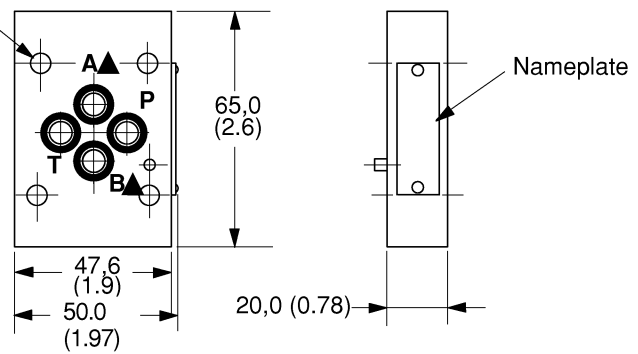

Subplates and Mounting Surfaces

General Description

If a subplate is not used, a machined pad must be provided for valve mounting. Pad must be flat within 0,0127 mm (.0005 inch) and smooth within 1,6 μm (63 microinch). Mounting bolts, when provided by customer, should be ISO 898 class 12.9 or better.

Dimensional Tolerances

Dimensional tolerance on interface drawings is $\pm 0,2$ mm (± 0.008 ") except where otherwise stated. ISO 4401 specifies inch conversion to ± 0.01 ".

Conversion from Metric

ISO 4401 gives dimensions in mm. Inch conversions are accurate to 0.01" unless otherwise stated.

Mounting Bolt Tappings

ISO 4401 gives metric thread tappings. Alternate UNC tappings are Vickers recommendations that allow these plates and associated valves to be used up to their maximum pressures, when using Vickers recommended bolt kits, or bolts of an equivalent strength. It is recommended that Customer's own manifold blocks for UNC bolts should be tapped to the minimum depths given in the footnotes.

Subplates

Description and Mass kg (lb)	Functional Symbol	Model Code	Max. Pressure
Single-station subplate; rear ports P, T, A, B; side port L Cast iron 1,3 (2.9)		KDGMV-3-1*-R▲ KDGMV-3-676803-1* (SAE/UNF ports)	250 bar (3600 psi)

*Design number subject to change. No change of installation dimensions for design numbers 10 to 19 or 21 to 29 inclusive.

▲ "S" suffix=SAE/UNC ports and/or UNC fixing bolt tappings and/or orifice plugs as appropriate.
"R" suffix=BSPF and/or metric fixing bolt tappings and/or orifice plugs as appropriate.

Interface with Additional Drain Port

The interface conforms to Vickers standard, plus hole "L"

Typically used for proportional and other valves requiring an additional drain port, e.g.:

K(B)FDG4V-3
K(B)FTG4V-3
K(B)SDG4V-3

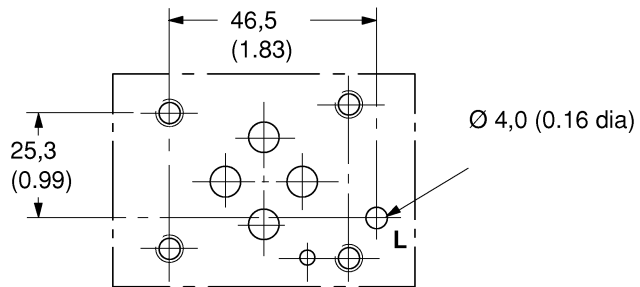

Installation Dimensions

Single-Station Subplates

All dimensions in mm (inches)

4 holes tapped according to model type (see table):
 For models with BSPF ports, M5 x 12 (0.47) deep
 For models with SAE ports, #10-24 UNC-2B x 12,7 (0.5) deep

4 system connections for rear-entry models, see table

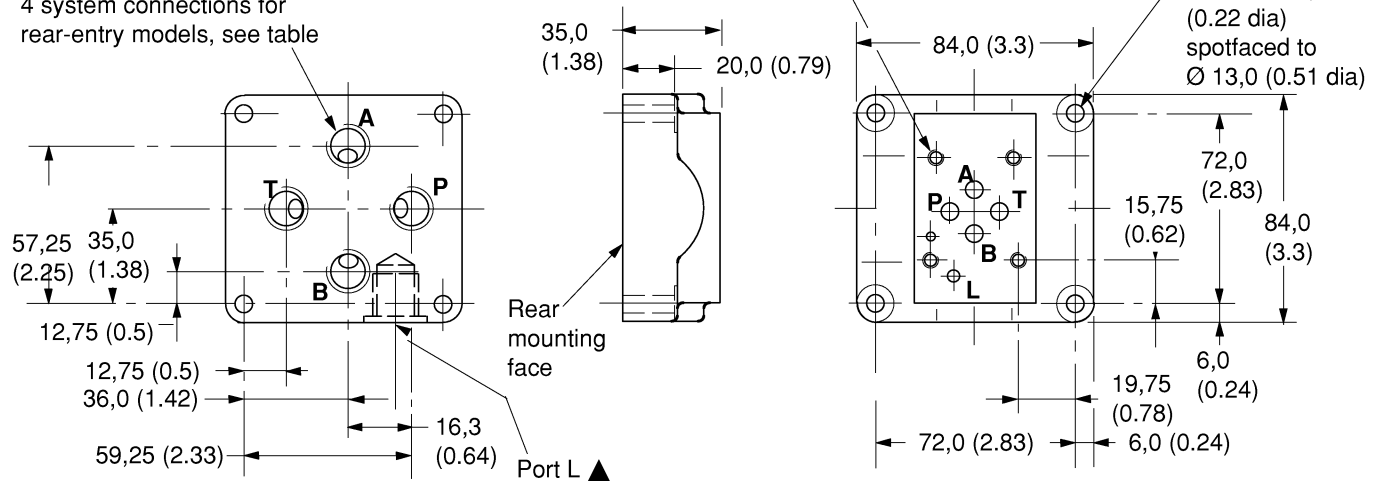

Port Threads

Model	Ports P, T, A, B	Port L
BSPF ports/M5 mounting bolts:		
KDGVM-3-1*-R	Rear G ^{3/8"} (3/8" BSPF) x 12,0 (0.47) deep	G ^{1/8"} (1/8" BSPF) x 12,0 (0.47) deep
SAE ports/#10-24 UNC mounting bolts:		
KDGVM-3-676803-1*	Rear 3/4"-16 UNF-2B x 14,3 (0.56) deep (SAE)	7/16"-20 UNF-2B x 11,6 (0.46) deep (SAE)

▲ 11,5 (0.45) from rear mounting face to port center line.

234.Mounting Surface to ISO 4401 (Size 03)

This interface conforms to:
 ISO 4401-03-02-0-94
 plus location pin hole
 ANSI/B93.7M (and NFPA) size 03
 CETOP R35H4.2-4-03, plus location
 pin hole
 DIN 24340 Form A6 plus location
 pin hole

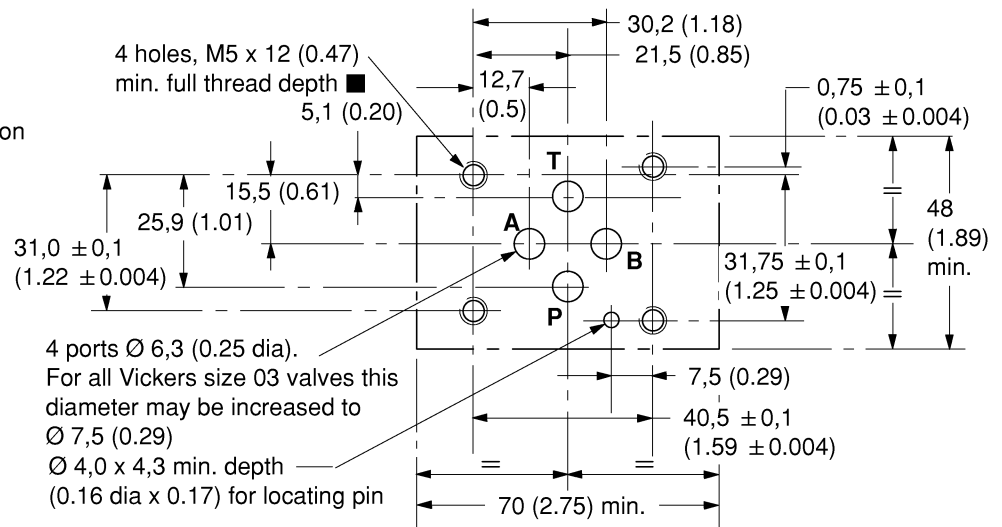

■ #10-24 UNC-2B optional.

Electrical Information

Electrical Block Diagram

KBFDG4V-3 and KBFTG4V-3

Command Signals and Outputs

7-pin plug		Flow direction
Pin D	Pin E	
Positive	0V	P to A
0V	Negative	
$U_D - U_E = \text{Positive}$		
Negative	0V	P to B
0V	Positive	
$U_D - U_E = \text{Negative}$		

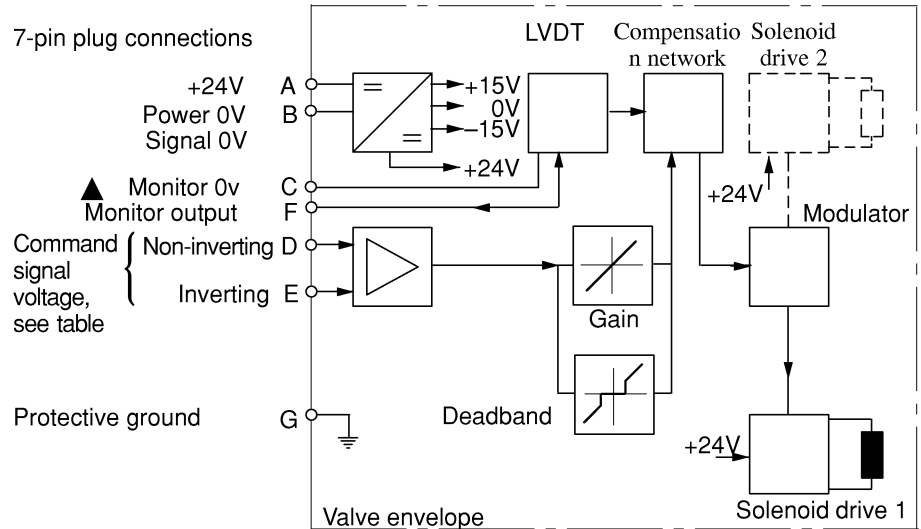

▲ *Note: In valves with PH7 or PR7 type electrical connection, pin C is used for a valve enable signal.*

Wiring

Connections must be made via the 7-pin plug mounted on the amplifier. See page 15 of this leaflet and Installation Wiring Practices for Vickers Electronic Products, leaflet 2468. Recommended cable sizes are:

Power cables:

For 24V supply
 0,75 mm² (18 AWG) up to 20m (65 ft)
 1,00 mm² (16 AWG) up to 40m (130 ft)

Signal cables:

0,50 mm² (20 AWG)

Screen (shield):

A suitable cable would have 7 cores, a separate screen for the signal wires and an overall screen.
 Cable outside diameter 8,0–10,5 mm (0.31–0.41 inches)
 See connection diagram on next page.

KFDG4V-3 and KFTG4V-3

Wiring

Wiring details for these valves are contained in the appropriate Eurocard literature and the Installation Wiring Practices for Vickers Electronic Products leaflet 2468.



Warning

All power must be switched off before connecting or disconnecting any plugs.

Typical Connection Arrangements

Wiring Connections

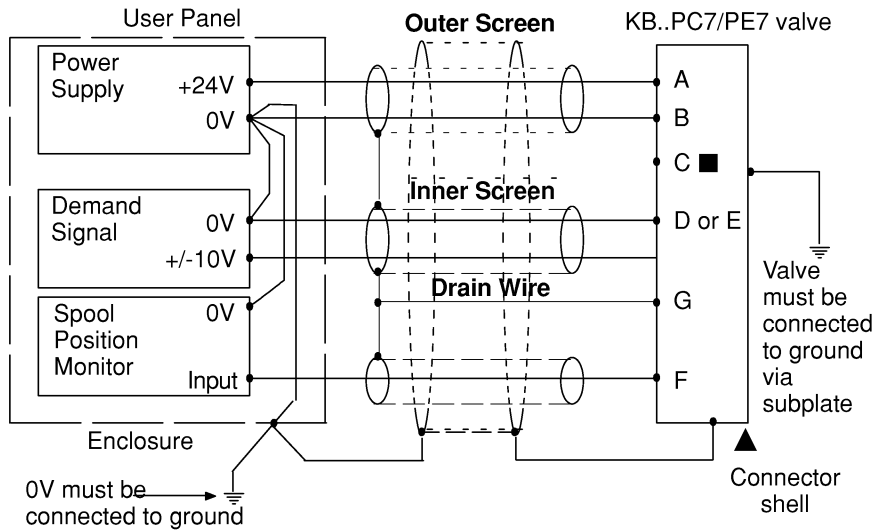

■ Spool position monitor voltage (pin F) will be referenced to the KB valve local ground. A "local ground" (pin C) is provided on PC7/PE7 versions for optional use by differential input customer supplied electronics.



WARNING

Do not ground pin C. If the local ground (pin C) is not used for differential monitor electronics, do not use. Read monitor pin F with respect to ground.

Wiring Connections for Valves with Enable Feature

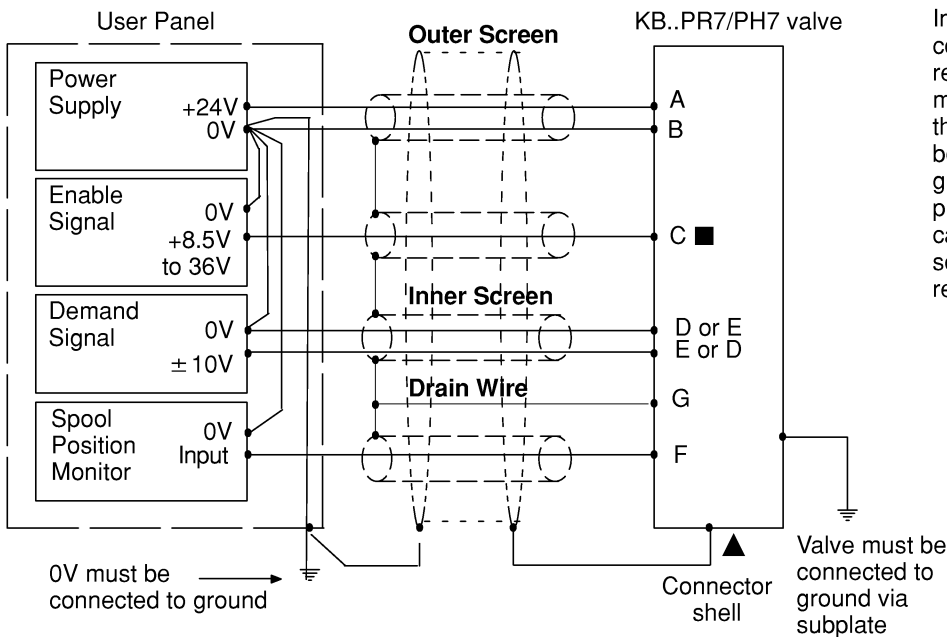

▲ Note:

In applications where the valve must conform to European RFI/EMC regulations, the outer screen (shield) must be connected to the outer shell of the 7 pin connector, and the valve body must be fastened to the earth ground. Proper earth grounding practices must be observed in this case, as any differences in command source and valve ground potentials will result in a screen (shield) ground loop.



Warning

Electromagnetic Compatibility (EMC)

It is necessary to ensure that the valve is wired up as above. For effective protection the user electrical cabinet, the valve subplate or manifold and the cable screens should be connected to efficient ground points. The metal 7 pin connector part no. 934939 should be used for the integral amplifier.

In all cases both valve and cable should be kept as far away as possible from any sources of electromagnetic radiation such as cables carrying heavy current, relays and certain kinds of portable radio transmitters, etc. Difficult environments could mean that extra screening may be necessary to avoid the interference.

It is important to connect the 0V lines as shown above. The multi-core cable should have at least two screens to separate the demand signal and monitor output from the power lines.

The enable line to pin C should be outside the screen which contains the demand signal cables.

Application Data

Fluid Cleanliness

Proper fluid condition is essential for long and satisfactory life of hydraulic components and systems. Hydraulic fluid must have the correct balance of cleanliness, materials and additives for protection against wear of components, elevated viscosity and inclusion of air.

Recommendations on contamination control methods and the selection of products to control fluid condition are included in Vickers publication 9132 or 561, "Vickers Guide to Systemic Contamination Control". The book also includes information on the Vickers concept of "ProActive Maintenance". The following recommendations are based on ISO cleanliness levels at 2 µm, 5 µm and 15 µm.

For products in this catalog the recommended levels are:

0 to 70 bar (1000 psi)	18/16/13
70 + bar (1000 + psi)	17/15/12

Vickers products, as any components, will operate with apparent satisfaction in fluids with higher cleanliness codes than those described. Other manufacturers will often recommend levels above those specified.

Experience has shown, however, that life of any hydraulic components is shortened in fluids with higher cleanliness codes than those listed below. These codes have been proven to provide a long trouble-free service life for the products shown, regardless of the manufacturer.

Hydraulic Fluids

Materials and seals used in these valves are compatible with antiwear hydraulic oils, and non-alkyl-based phosphate esters. The extreme operating viscosity range is 500 to 13 cSt (2270 to 70 SUS) but the recommended running range is 54 to 13 cSt (245 to 70 SUS).

Installation

The proportional valves in this catalog can be mounted in any attitude, but it may be necessary in certain demanding applications, to ensure that the solenoids are kept full of hydraulic fluid. Good installation practice dictates that the tank port and any drain port are piped so as to keep the valves full of fluid once the system start-up has been completed.

Mounting Bolt Kits

For K(B)FD/TG4V-3

BK02-156493M (metric)
BK590716 (inch)

If not using Vickers recommended bolt kits, bolts used should be to ISO 898, 12.9 or better.

Seal Kits

KFD/TG4V-3 565108
KBFD/TG4V-3-1* 02-332693

Plugs

KBFDG4V
7-pin plug (metal) 934939
7-pin plug (plastic) 694534
(NOTE: Metal plug must be used for full EMC protection)

NOTE: An alternative metal connector which gives EMC protection but not IP67 rating is available from ITT-Cannon, part number CA06-COM-E-14S-A7-S.

KFDG4V
Solenoid (black) 710775
Solenoid (gray) 710776
LVDT (gray) 458939

Extension Cable

Extension Cable: Adapter for extending 7 core cable when changing from KA to KB valve and existing wiring is not long enough. Consists of a 7 pin plug, a 7 pin socket and a length of cable, fully assembled for ease of use
Extension Cable 944450

Service Information

The products from this range are preset at the factory for optimum performance; disassembling critical items would destroy these settings. It is recommended that if any mechanical or electronic repair is necessary, valves should be returned to the nearest Vickers repair center. The products will be refurbished as necessary and retested to specification before return.

Field repair is restricted to replacement of the seals.

Note: The feedback/solenoid assembly installed in this valve should not be disassembled.